



## SINGLE BANK BAGEL MACHINE **EMP-SD-SF**



### World's Favorite Bagel Machine

Empire's **Single Bank Bagel Machine EMP-SD-SF** is the most effective, quickest and easiest to manage bagel system on the market today. It's variable knife speed give you control and accuracy in the most arduous bagel production lines. The **EMP-SD-SF** is easy to operate and a snap to clean. Together this bagel divider/former duo make up the industries top selling and most reliable bagel production machine on the market.

The industry standard for retail, foodservice and small wholesale operations, Empire's **Single Bank Bagel Machine EMP-SD-SF** produces up to 3,600 consistent bagels per hour. Available with a variety of mandrel and sleeve sizes to produce everything from the popular "minis" and robust "bulls".

### Features

- ◆ Produces up to 3,600 Pieces/Hour
- ◆ Rotary Knife Action - No Piston or Messy Oil Clean Up
- ◆ No Heat Transfer from Machine to Dough
- ◆ Includes Standard Forming Tube Mini and Bull Bagel Set-Ups Available
- ◆ Mounted Casters for Easy Movement and Cleaning
- ◆ Variable Speed on Knife
- ◆ 20 in. Turntable for Easy Accessibility and Panning
- ◆ Easily Adjusted Pressure Plate
- ◆ Belt Tension Adjustment For Extended Belt Life
- ◆ Board Holder included
- ◆ Turntable for Easy Accessibility and Panning

# Technical Data

## SINGLE BANK BAGEL MACHINE EMP-SD-SF

Model	Capacity	Dimensions			Weight	HP	Electrical	
		Length	Width	Height			Voltage	Min. Amps
		in.	in.	in.	lbs.			
<b>EMP-SD-SF</b> Single Divider/Former	3,600/hr	114	30	57	1,000	3/4 HP / 1HP	208-220V / 3Ph/60Hz	20 A

Forming Tubes	Tube Size	Mandrel Size	Range
	in.	in.	oz.
Standard Bagel Setup*	9"	1 5/8	3 3/4 - 4 1/2
Mini Bagel Setup	8"	1 1/2	2 - 3
Bull Bagel Setup	10"	1 7/8 or 2	5 - 5 1/2

\*Standard Bagel Setup Included; Mini & Bull Setups are Optional

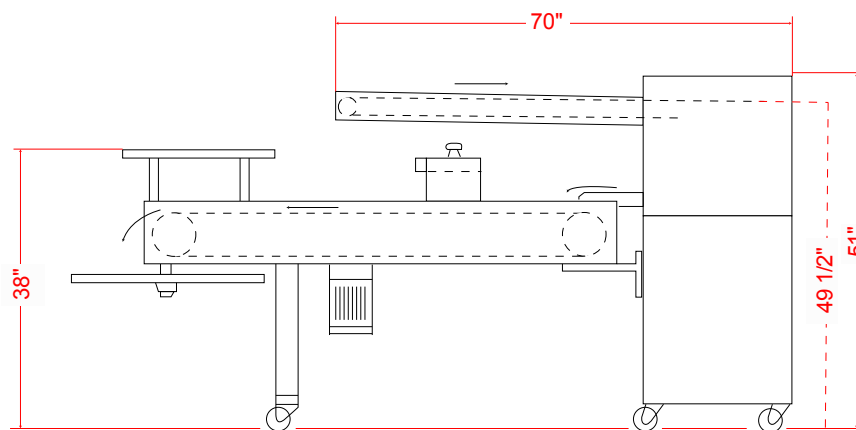
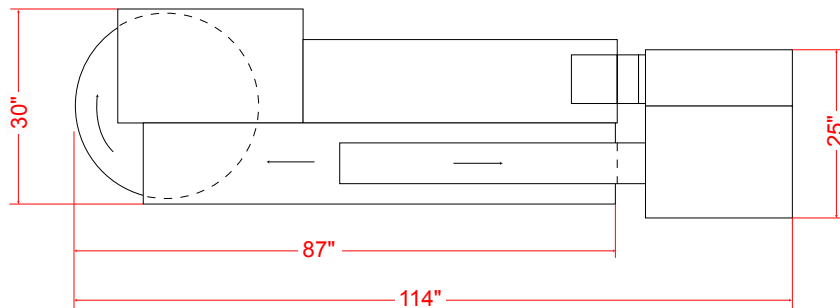

### LIMITED WARRANTY

This product is warranted to the original purchaser to be free from material and workmanship defects. This warranty extends for a period of one (1) year from the date of purchase on parts and labor and 90 days on electrical components. For additional information or if you have any questions, please do not hesitate to contact us toll free at 1-800-878-4070.

Please note, specifications are subject to change without notice as we continually work to improve our equipment.



1C Enterprise Place, Hicksville, NY 11801-5356 ♦ Ph: (516) 681-1500 ♦ Fx: (516) 681-1510  
1-800-878-4070 ♦ www.empirebake.com ♦ info@empirebake.com